

**Flame Sensor FFS 06,
FFS 06 UV-1 and FFS 06 UV-2**

for Flame Detector Device F 150
and Etamatic



Criterion for selection of Flame Sensors

Sensor type	for radiated spectrum of	Application - Fuel
FFS 06 UV-1	260 ... 400 nm	Oil, gas
FFS 06 UV-2	210 ... 380 nm	Oil, gas (special gases, ie. refinery – and blast furnace gases)
FFS 06	1200 ... 2800 nm	Oil, gas, with a high volume of flue gas recirculation, waste gases with yellow colour without UV-radiation.

Installation and operation of the Flame Sensor

Mount the Flame Sensor with its prepared holding device to the sight aperture of the burner, that the flame is to be monitored and good visible over the full range of the burner firing capacity. The IR-Flame Sensor FFS 06 sensitivity adjustment for the burner flame is done by threshold-switches (DIP) inside the Flame Sensor housing. Therefore screw off the sensor housing and adjust these threshold switches according following illustration. The location of these DIP-switches are on the rear soldering side of the PCB, on which the IR-sensor element is fixed.

IR- Flame Sensor FFS 06

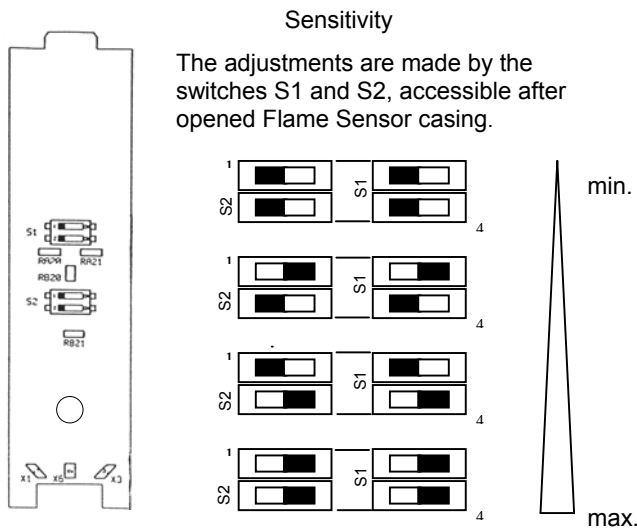

The min. threshold value for IR-Flame Sensors are 15 mV and for UV-Flame Sensors 25 mV.

Further information for operation of the Flame Sensors are given in the technical documentation for the Flame Detector Devices.

Attention: The FFS 06 UV-Flame Sensors do not have these threshold switches for sensitivity adjustment. To achieve here the optimum and optimum angle of incidence for monitoring the flame, the sensor signal voltage can be measured for its maximum.

Dimension drawing and wiring assignment

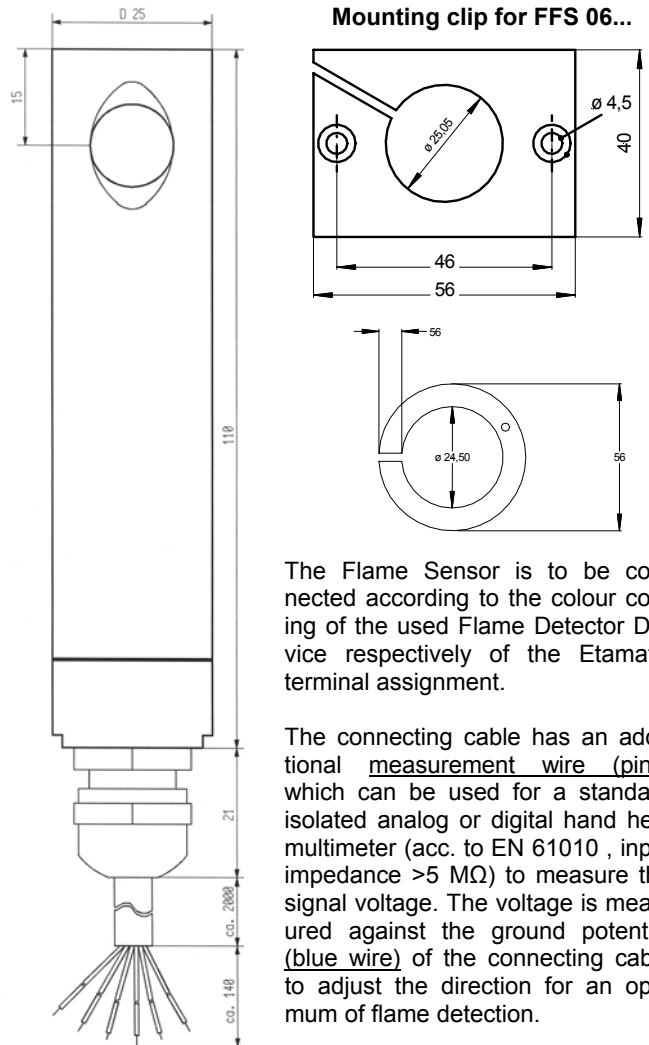

Weight: 0,4 kg
 Protection class: IP 65
 Ambient temperature: -10°C ... +60 °C

Order text information

The Flame Sensors are delivered with and without the Coninvers plug, incl. 2 m connecting cable. Is the Flame Sensor ordered with the Coninvers plug, than an additional connector plug incl. 3m connecting cable (659 R 3112) is required and has to be ordered too.

FFS 06	without plug, 2 m cable	659 R 3001	FFS 06	with plug, 2 m cable	659 R 3007
FFS 06 UV-1	without plug, 2 m cable	659 R 3002	FFS 06 UV-1	with plug, 2 m cable	659 R 3008
FFS 06 UV-2	without plug, 2 m cable	659 R 3005	FFS 06 UV-2	with plug, 2 m cable	659 R 3009
Mounting clip		659 R 0108	Coninvers couple connector with 3 m cable		659 R 3112



LAMTEC Meß- und Regeltechnik für Feuerungen GmbH & Co KG
 Impexstraße 5
 D-69190 Walldorf
 Telefon (+49) 0 62 27 / 60 52-0
 Telefax (+49) 0 62 27 / 60 52-57
 Internet <http://www.lamtec.de>
 E- Mail: info@lamtec.de

LAMTEC Leipzig GmbH & Co KG

Schlesierstraße 55
 D-04299 Leipzig
 Telefon (+49) 03 41 / 86 32 94 00
 Telefax (+49) 03 41 / 86 32 94 10

Brochure no. DLT 7502-04E-0002
 Printed in Germany